

## City of Sheridan

### Moroe & Bridge St/ Harney & Bridge ST ADA Improvements Engineer's Estimate

Item #	Description	Unit	Estimated Quantity	Unit Price	Total Estimated Price
1	Mobilization, Bonding and Insurance (10%)	LS	1	\$ 7,017.19	\$ 7,017.19
2	Construction Facilities and TPAR (5%)	LS	1	\$ 3,508.60	\$ 3,508.60
3	Demolition and Site Prep (10%)	LS	1	\$ 7,017.19	\$ 7,017.19
4	Bike Rack	EA	2	\$ 1,000.00	\$ 2,000.00
5	5" Channel Drain	EA	1	\$ 1,000.00	\$ 1,000.00
6	Stamped Concrete	SF	268	\$ 25.00	\$ 6,700.00
7	Concrete Side Walk	SF	1377	\$ 15.00	\$ 20,655.00
8	TYP. Concrete Curb and Gutter	LF	185	\$ 35.00	\$ 6,475.00
9	Continental Strip	LF	148	\$ 12.00	\$ 1,776.00
10	G1 Catch Basin	EA	2	\$ 2,500.00	\$ 5,000.00
11	Truncated Dome	EA	7	\$ 3,000.00	\$ 21,000.00
12	4" SDR 35	LF	5	\$ 15.00	\$ 75.00
13	Sawcut	LF	269.88	\$ 5.00	\$ 1,349.40
14	Valley Gutter	LF	20	\$ 40.00	\$ 800.00
15	Site Clean-up	LS	1	\$ 3,341.52	\$ 3,341.52
Contingency (10%)			10%	\$	<b>8,771.49</b>
Construction Management		T&M	10%	\$	<b>13,157.24</b>
<b>Total =</b>				\$	<b>109,643.63</b>



City of Sheridan - Sheridan Road Impr. Preliminary Cost Estimate  
 11/3/2023  
 LENGTH: 4008 FT  
 NO. OF INTERSECTIONS: 9

No.	Description	Unit	Qty	Unit Price	Total
<b>GENERAL</b>					
1	MOBILIZATION BONDS AND INSURANCE	LS	1	13%	\$1,058,520
2	TEMPORARY FACILITIES AND CONTROLS	LS	1	5%	\$407,123
3	DEMOLITION AND SITE PREP	LS	1	2%	\$162,849
4	LANDSCAPE RESTORATION	LS	1	1%	\$81,425
5	TRAFFIC CONTROL	LS	1	5%	\$407,123
<b>GENERAL SUBTOTAL:</b>					\$2,117,040
<b>WATER (Jesse Rodriguez Const. Bid, 7-25-24)</b>					
6	MOBILIZATION, BONDING AND INSURANCE	LS	1	\$ 170,000.00	\$ 170,000.00
7	CONSTRUCTION FACILITIES AND TEMP. CONTROLS	LS	1	\$ 45,000.00	\$ 45,000.00
8	DEMOLITION AND SITE PREP	LS	1	\$ 35,000.00	\$ 35,000.00
9	FIRE HYDRANT ASSEMBLY	EA	9	\$ 8,875.00	\$ 79,875.00
10	WATER METER RECONNECTION	EA	68	\$ 1,600.00	\$ 108,800.00
11	4" X 2" FLG X MJ REDUCER	EA	1	\$ 100.00	\$ 100.00
12	14" X 10" FLG REDUCER	EA	1	\$ 997.00	\$ 997.00
13	4" X 2" FLG X MJ TEE	EA	1	\$ 486.00	\$ 486.00
14	10" X 4" FLG TEE	EA	1	\$ 740.00	\$ 740.00
15	14" MJ x FLG TEE	EA	1	\$ 1,927.00	\$ 1,927.00
16	14" X 4" FLG TEE	EA	2	\$ 1,760.00	\$ 3,520.00
17	14" X 6" FLG TEE	EA	4	\$ 1,523.00	\$ 6,092.00
18	14" X 10" FLG TEE	EA	2	\$ 1,624.00	\$ 3,248.00
19	2" FLG GATE VALVE	EA	1	\$ 775.00	\$ 775.00
20	4" FLG X MJ GATE VALVE	EA	1	\$ 1,173.00	\$ 1,173.00
21	4" FLG GATE VALVE	EA	1	\$ 1,175.00	\$ 1,175.00
22	6" FLG GATE VALVE	EA	1	\$ 1,524.00	\$ 1,524.00
23	6" FLG x MJ GATE VALVE	EA	2	\$ 2,841.00	\$ 5,682.00
24	10" FLG GATE VALVE	EA	1	\$ 3,400.00	\$ 3,400.00
25	10" FLG X MJ GATE VALVE	EA	2	\$ 3,268.00	\$ 6,536.00
26	14" FLG X MJ GATE VALVE	EA	15	\$ 11,458.00	\$ 171,870.00
27	4" FLG X MJ ADAPTER	EA	1	\$ 199.00	\$ 199.00
28	10" FLG ADAPTER	EA	2	\$ 630.00	\$ 1,260.00
29	10" FLG X MJ ADAPTER	EA	1	\$ 630.00	\$ 630.00
30	14" FLG X MJ ADAPTER	EA	1	\$ 771.00	\$ 771.00
31	4" 11 1/4" MJ ELBOW	EA	1	\$ 188.00	\$ 188.00
32	14" 11 1/4" FLG X MJ ELBOW	EA	1	\$ 2,865.00	\$ 2,865.00
33	14" 11 1/4" MJ ELBOW	EA	1	\$ 1,179.00	\$ 1,179.00
34	6" 22 1/2" FLG x MJ ELBOW	EA	2	\$ 162.00	\$ 324.00
35	2" FLG x MJ 45° ELBOW	EA	1	\$ 3.50	\$ 3.50
36	2" MJ 45° ELBOW	EA	1	\$ 3.50	\$ 3.50
37	6" 45° MJ ELBOW	EA	2	\$ 269.00	\$ 538.00
38	6" 45° MJ x FLG ELBOW	EA	2	\$ 226.00	\$ 452.00
39	10" 45° FLG x MJ ELBOW	EA	1	\$ 592.00	\$ 592.00
40	14" MJ 45° ELBOW	EA	6	\$ 1,098.00	\$ 6,588.00
41	14" FLG X MJ 45° ELBOW	EA	2	\$ 1,361.00	\$ 2,722.00
42	4" 90° MJ ELBOW	EA	1	\$ 208.00	\$ 208.00
43	6" x 2" REDUCER	EA	1	\$ 271.00	\$ 271.00
44	2" SPOOL	EA	2	\$ 63.00	\$ 126.00
45	4" SPOOL	EA	4	\$ 92.00	\$ 368.00
46	6" SPOOL	EA	4	\$ 124.00	\$ 496.00
47	10" SPOOL	EA	1	\$ 637.00	\$ 637.00
48	14" SPOOL	EA	6	\$ 1,678.00	\$ 10,068.00
49	2" TRANSITION COUPLING	EA	1	\$ 118.00	\$ 118.00
50	4" TRANSITION COUPLING	EA	2	\$ 348.00	\$ 696.00
51	6" TRANSITION COUPLING	EA	3	\$ 480.00	\$ 1,440.00
52	10" TRANSITION COUPLING	EA	1	\$ 684.00	\$ 684.00

Does not include water and sewer. Those overhead costs are already included within those categories.

53	14" TRANSITION COUPLING	EA	2	\$ 1,263.00	\$ 2,526.00
54	10" BLIND FLG	EA	3	\$ 374.00	\$ 1,122.00
55	6" PVC WATERLINE	LF	93	\$ 225.00	\$ 20,925.00
56	10" PVC WATERLINE	LF	20	\$ 350.00	\$ 7,000.00
57	14" PVC WATERLINE	LF	4,072	\$ 158.00	\$ 643,376.00
<b>WATER SUBTOTAL:</b>					\$1,356,296
<b>STORM SEWER</b>					
58	24" CATCH BASIN - TYPE 2	EA	24	\$2,900	\$69,600
59	48" MANHOLE, 0-8' DEEP	EA	19	\$6,000	\$114,000
60	24" 3034 PVC STORM DRAIN PIPE	LF	4603	\$200	\$920,600
61	6" 3034 STORM DRAIN PIPE	LF	1153	\$100	\$115,300
62	CONNECT TO EXISTING - STORM	EA	10	\$1,200	\$12,000
63	CONSTRUCT INFILTRATION BASIN, COMMON EX.	CY	2571.222222	\$25	\$64,281
64	SEED INFILTRATION BASIN	AC	0.666345271	\$10,000	\$6,663
65	24" STORMWATER OUTFALL HEADWALL WITH ENERGY DISSIPATOR	EA	1	\$6,000	\$6,000
66	48" DIA INLET SKIMMER STRUCTURE	EA	1	\$6,000	\$6,000
<b>STORM SEWER SUBTOTAL:</b>					\$1,314,444
<b>SANITARY SEWER (Jesse Rodriguez Const. Bid, 7-25-24)</b>					
67	SANITARY SEWER CIPP, 8" CONCRETE PIPE	LF	982	\$ 68.00	\$ 66,776.00
68	SANITARY SEWER CIPP, 12" CONCRETE PIPE	LF	1,818	\$ 75.00	\$ 136,350.00
69	SANITARY SEWER CIPP, 15" CONCRETE PIPE	LF	2,450	\$ 87.00	\$ 213,150.00
70	Service Reinstatement - Grout	EA	68	\$ 1,096.00	\$ 74,528.00
71	SANITARY SEWER SERVICE LATERAL TOP-HAT LINER	EA	68	\$ 3,000.00	\$ 204,000.00
<b>SANITARY SEWER SUBTOTAL:</b>					\$694,804
<b>STREETS</b>					
72	COLD PLANE REMOVAL OF ASPHALT	SY	16151	\$4	\$64,605
73	COMMON EXCAVATION, 34' STREET	CY	8076	\$25	\$201,892
74	COMMON EXCAVATION, 41' STREET	CY	9634	\$25	\$240,858
75	CURB AND GUTTER	LF	8131	\$65	\$528,515
76	CONCRETE DRIVEWAY APPROACHES	SF	559	\$30	\$16,770
77	5' WIDE SIDEWALK	SF	40262	\$11	\$442,882
78	8' WIDE SIDEWALK	SF	52286	\$11	\$575,146
79	ADA RAMPS	EA	21	\$6,200	\$130,200
80	6" ASPHALT PAVING, 34' WIDTH	TN	5088	\$100	\$508,800
81	6" ASPHALT PAVING, 41' WIDTH	TN	6070	\$100	\$607,000
82	12" AGGREGATE BASE, 34' WIDTH	TN	8722	\$30	\$261,660
83	12" AGGREGATE BASE, 41' WIDTH	TN	10406	\$30	\$312,180
84	4" WIDE THERMOPLASTIC PAVEMENT MARKINGS	LF	16032	\$2	\$25,651
85	12" THERMOPLASTIC PAVEMENT MARKINGS	LF	924	\$9	\$8,316
86	THERMOPLASTIC SHARROW MARKING	EA	33	\$250	\$8,250
87	MISC SIGNS	EA	18	\$500	\$9,000
88	STREET LIGHTS WITH BASE	EA	25	\$1,400	\$35,000
89	2" SCH40 PVC STREET LIGHT CONDUIT	LF	4631	\$18	\$83,358
90	ELECTRICAL PULL BOX - STREET LIGHTS	EA	12	\$400	\$4,800
<b>STREETS SUBTOTAL:</b>					\$4,064,884
<b>PRIVATE UTILITY UNDERGROUNDING</b>					
91	3" SCH40 ELECTRICAL CONDUIT	LF	16262	\$21	\$341,502
92	2" SCH40 CABLE AND TELECOMMUNICATION CONDUIT	LF	32524	\$18	\$585,432
93	INSTALLATION OF ELECTRICAL SWITCH GEAR (PROVIDED BY OTHERS)	EA	21	\$1,100	\$23,100
94	INSTALLATION OF ELECTRICAL TRANSFORMER BASE (PROVIDED BY OTHERS)	EA	21	\$1,100	\$23,100
95	INSTALLATION OF SMALL VAULT (PROVIDED BY OTHERS)	EA	10	\$5,000	\$50,000
96	INSTALLATION OF MEDIUM VAULT (PROVIDED BY OTHERS)	EA	5	\$10,000	\$50,000
97	INSTALLATION OF LARGE VAULT (PROVIDED BY OTHERS)	EA	1	\$15,000	\$15,000
98	INDIVIDUAL PROPERTY SERVICE CONVERSION (ESTIMATE BETWEEN \$10-25K PER PROPERTY)	EA	67	\$25,000	\$1,675,000
<b>UTILITY UNDERGROUNDING SUBTOTAL:</b>					\$2,763,134
<b>SUB-TOTAL: \$12,310,602</b>					
<b>CONTINGENCY (30%): \$3,077,850</b>					
<b>ENGINEERING/ LEGAL/ ADMIN (17%): \$2,092,802</b>					
<b>TOTAL W/CONTINGENCY: \$17,481,254</b>					

Does not include contingency for water and sewer  
includes all project costs

City of Sheridan - Hebert Plaza Sidewalk Improvements Cost Estimate  
8/29/2024

No.	Description	Unit	Qty	Unit Price	Total
<b>GENERAL</b>					
1	MOBILIZATION BONDS AND INSURANCE	LS	1	13%	\$16,130
2	TEMPORARY FACILITIES AND CONTROLS	LS	1	5%	\$6,204
3	DEMOLITION AND SITE PREP	LS	1	2%	\$2,482
4	LANDSCAPE RESTORATION	SF	18737	77%	\$14,427
6	EARTHWORK	CY	584	\$80	\$46,720 *
7	4" CONCRETE SIDEWALK WITH 4" AGGREGATE BASE	SF	2416	\$20	\$48,320 **
8	4" ASPHALT TRAIL WITH 8" AGGREGATE BASE	SY	140	\$49	\$6,888 *
9	CONCRETE CURB, TYPE C	LF	130	\$40	\$5,200 *
10	1"-0 AGGREGATE BASE	TN	42	\$60	\$2,520 *
<b>SUB-TOTAL:</b>					<b>\$148,891</b>
<b>CONTINGENCY (10%):</b>					<b>\$14,889</b>
<b>ENGINEERING/ LEGAL/ ADMIN (10%):</b>					<b>\$14,889</b>
<b>TOTAL:</b>					<b>\$178,669</b>

earthwork	584	cy
disturbed area:	18737	sf
Hebert sidewalk	1552	sf
river access trail	140	sy
landing	390	sf
type c curb	130	lf
concrete retaining wall	2750	sf
8" n12 culvert	11	lf
parking lot sidewalk	474	sf

TRAIL		BASE (8")		
ASPHALT (4")	CF/SY	6.0	CF/SY	
3.0	LB/CF	110	LB/CF	1.485 TN/CY
140	LB/SY	660.0	LB/SY	
420.0	TN/SY	0.330000165	TN/SY	
0.20999979	COST/TN	60	COST/TN	*
\$140	COST/SY	\$20	COST/SY	
\$29				

SEEDING	
\$33,500	COST/ACRE *
\$0.77	COST/SF

\*2024 odot bid tabulation summary  
\*\* 2023 SE Moore Overlay, Newport



To: Sheridan City Council  
From: Heidi Bell, City Manager  
Date: September 9, 2024  
RE: Item C1) Vote: Award Bid for ADA Improvements on Bridge Street

**Council Strategic Plan:** Infrastructure Investment

**Overview:**

As directed by the City Council, staff have engaged with the city engineers to address pedestrian safety concerns at the intersections of Bridge Street and Harney Street, funded between IGA and Country Bargains. Additionally, during these discussions, the intersection of Bridge Street and Monroe Street, near Subway, was also addressed. To optimize project efficiency and reduce fixed construction costs, such as mobilization fees, these two intersections will be consolidated into a single project, referred to hereafter as the "Bridge Street Pedestrian Project."

At this meeting, the engineers will provide a detailed overview of the bidding process, the scope of work, associated costs, and potential cost-saving measures. They will also be available to answer any questions the Council may have.

**Funding Considerations:**

I would like to bring to your attention the current budgetary constraints. All street projects are funded through the Street Budget, with a significant portion of these funds already allocated to the Sheridan Road Project. Unfortunately, the available budget is insufficient to cover both the surface improvements for Sheridan Road and the Bridge Street Pedestrian Project, potentially delaying the Sheridan Road Project even further.

Given the escalating costs associated with the Sheridan Road Project, the City may need to consider extending the savings period or securing outside loans to fully fund it. A portion of the funding for the Sheridan Road surface improvements, approximately \$1.3 million, has been earmarked from the City's share of the American Rescue Plan Act (ARPA) funds. These funds must be expended by October 2025 to ensure compliance with reporting requirements to auditors, as well as state and federal agencies. Ideally, we should aim to close out this funding earlier.

I propose that the Council consider reallocating the ARPA funds to cover the costs of the Bridge Street Pedestrian Project, and to address the water line repairs, sewer line repairs, and potential upgrades at Hebert Memorial Plaza on Sheridan Road. Given the time constraints, it may not be feasible to apply ARPA funds to the Sheridan Road surface improvements.

The funding for the Plaza repairs is currently designated to come from the General Fund's Park Department (System Development Fund) budget, which is approximately \$219,000.

### **Request for Council Direction:**

**Q: Comprehensive Cost Analysis:** Would the Council like me to prepare a detailed cost analysis for the September work session, covering all the projects and potential funding packages? Due to recent sick leave, I require additional office time with City finance to gather detailed information. If this is the preferred course of action, I recommend postponing the award of the bid for the Bridge Street Pedestrian Project.

### **Council Options:**

- **Award the Bid:** Proceed with awarding the bid for the Bridge Street Pedestrian Project. Council must determine whether to utilize ARPA funds or Street Funds for this project. Awarding the bid acknowledges the prioritization of the Bridge Street Pedestrian Project over the Sheridan Road resurfacing and pedestrian improvements.
- **No Action:** Direct the City Manager to prepare a comprehensive cost analysis and funding options for the Sheridan Road Project, Bridge Street Pedestrian Project, and Hebert Memorial Plaza. Note that the Plaza project has not yet gone out for bid, although an engineering estimate is available.
- **Rebid the Project:** Consider requesting that the engineers go back out for bid during the late fall/winter, as bids obtained during the summer are typically higher. This approach may also provide time to hire a Finance Director, thereby allowing for more dedicated staff time to finalize funding details.
- **Alternative Option:** Council may propose another course of action as deemed appropriate.



**Rogue Valley Office**  
 830 O'Hare Parkway Suite 102  
 Medford, OR 97501  
 541-326-4828

**South Coast Office**  
 486 'E' Street  
 Coos Bay, OR 97420  
 541-266-8601

**Willamette Valley Office**  
 200 Ferry Street SW  
 Albany, OR 97321  
 541-223-5130

**North Coast Office**  
 409 SW 10th Street  
 Newport, OR 97366  
 541-264-7040

Date: August 19th, 2024

Project Number: 2820-009

To: Heidi Bell, City Manager, City of Sheridan

From: Chris Janigo, PE, LSI, Civil West Engineering Services, Inc. (CWES)

RE: **Bridge Street ADA Improvements Bid Opening**

**Summary**

Bids were opened for this project on Thursday, July 16, 2024, at 2:30 p.m. at the City of Sheridan City Hall. Two bids were received and are summarized below:

Contractor	Bid Price	Bid Alt #1	Bid Alt #2	Bid Alt #3	Bid Alt #4	Apparent Low Bidder
Turney Excavating Inc.	<b>\$ 105,197.00</b>	\$ 14,144.00	\$ 1,500.00	\$ 16,028.00	\$ 15,883.00	
Pihl Inc.	<b>\$ 119,500.00</b>	\$ 12,300.00	\$ 8,400.00	\$ 29,048.00	\$ 29,390.00	

The low bid was received by Turney Excavating Inc. in the amount of \$105,197.

**Options and Proposed Motions**

The City Council has three options to consider:

1. The City Council can opt to reject all bids then either rebid the project or wait/abandon the project. If the City chooses to reject all bids, the following motion can be used:

*I move to reject all bids for the Bridge Street ADA Improvement Project.*

2. The City Council may desire to fund the project. If this is the case, the City would accept the low bid proposal and issue a notice of intent to award the contract. State Procurement rules require the contracting agency to provide other bidders with 7-days to protest the intended award. At the end of 7-days, assuming there is no protest, the City can execute a contract with the low bidding contractor. If the Council desires to award the contract, the following motion can be used:

*I move to issue a Notice of Intent to Award a contract for the construction of the Bridge Street ADA Improvements to Turney Excavating Inc. in the amount of \$105,197 and, if no protests are received within the 7-day protest period, authorize the execution of the construction contract.*

3. The City Council can choose to accept a bid with selected bid alternatives (see attached figures) and go forward with the project. If this is the case, then the City would accept the low bid proposal and issue a notice of intent to award the contract. State Procurement rules require the contracting agency to provide other bidders 7-days to protest the intended award. At the end of 7-days, assuming there is no protest, the City can execute a contract with the low bidding contractor. If the Council desires to award the contract, the following motion can be used:

*I move to issue a Notice of Intent to Award a contract for the construction of the Bridge Street ADA Improvements including the following bid alternatives:*

1. **Bid Alternative 1:** Stamped Concrete panels (Fig. 1-2) - \$14,144.00
2. **Bid Alternative 2:** Bike Racks (Fig. 3-5) - \$1,500.00
3. **Bid Alternative 3:** S Bridge St & SW Monroe St SW Corner ADA Ramp (Fig. 6) - \$16,028.00
4. **Bid Alternative 4:** S Bridge St & SW Monroe St NW Corner ADA Ramp (Fig. 7) - \$15,883.00

*to Turney Excavating Inc. in the amount of \$\_\_\_\_\_ and, if no protests are received within the 7-day protest period, authorize the execution of the construction contract.*

Sincerely,

Chris Janigo, PE, LSI  
Civil West Engineering Services, Inc.  
[cjanigo@civilwest.net](mailto:cjanigo@civilwest.net)

Attach: Bid Tabulation, Figures 1-8

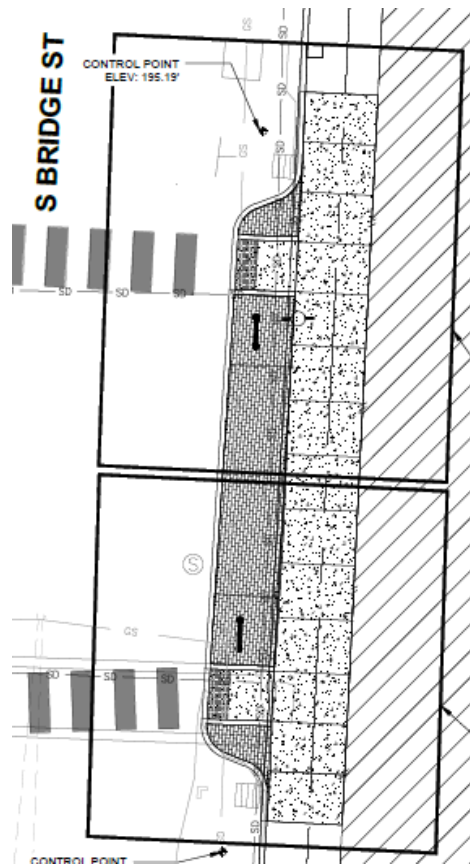

Figure 1. S Bridge St Stamped Concrete (Bid Alt 1)

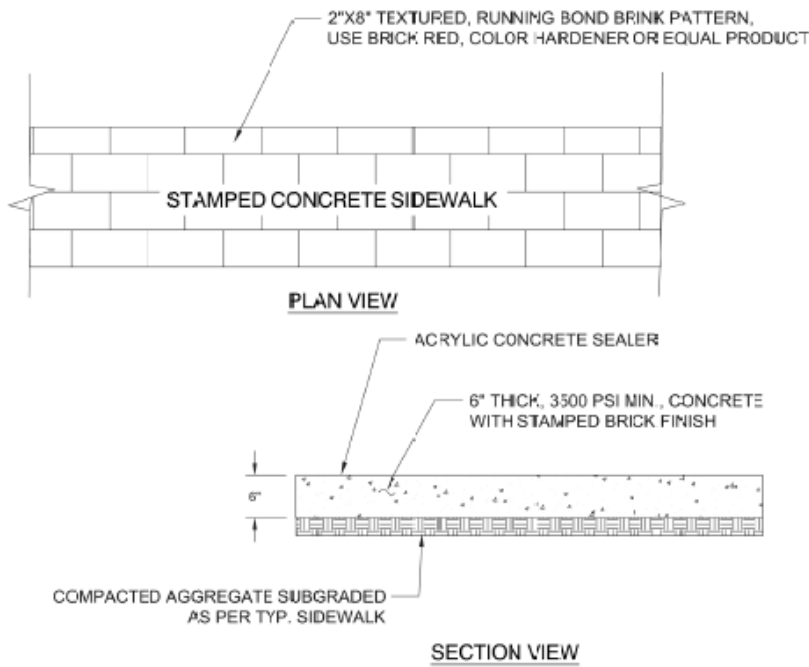

Figure 2. Stamped Concrete Details (Bid Alt 1)

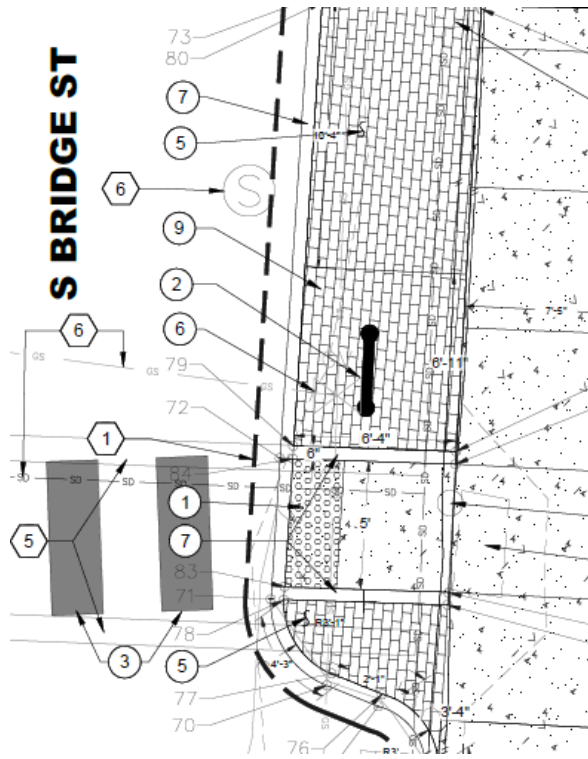

Figure 3. S Bike Rack Location (Bid Alt 2)

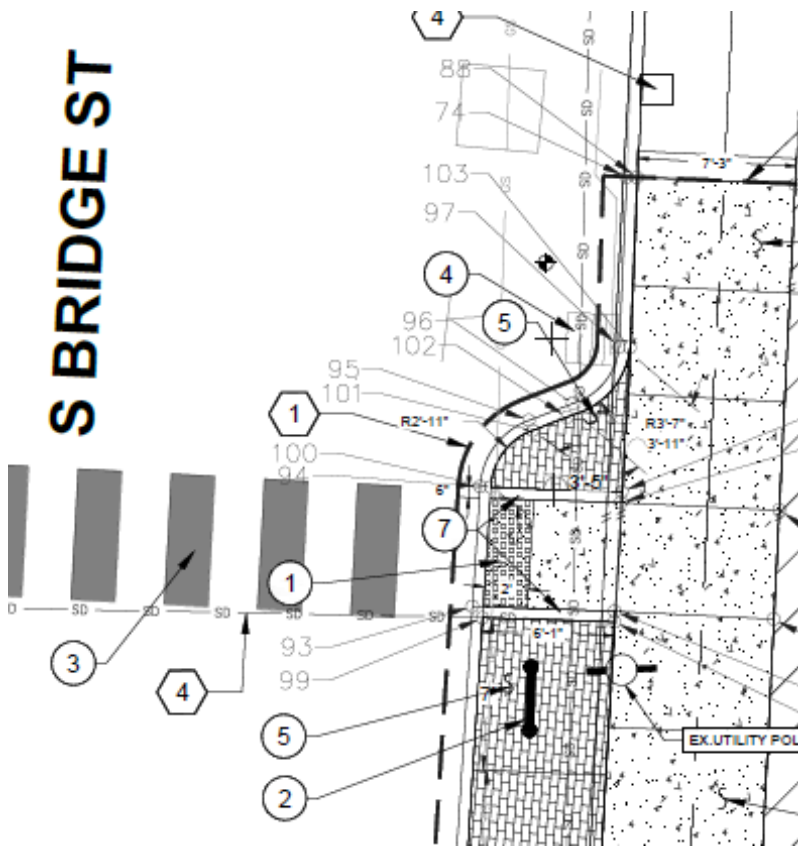

Figure 4. N Bike Rack Location (Bid Alt 2)

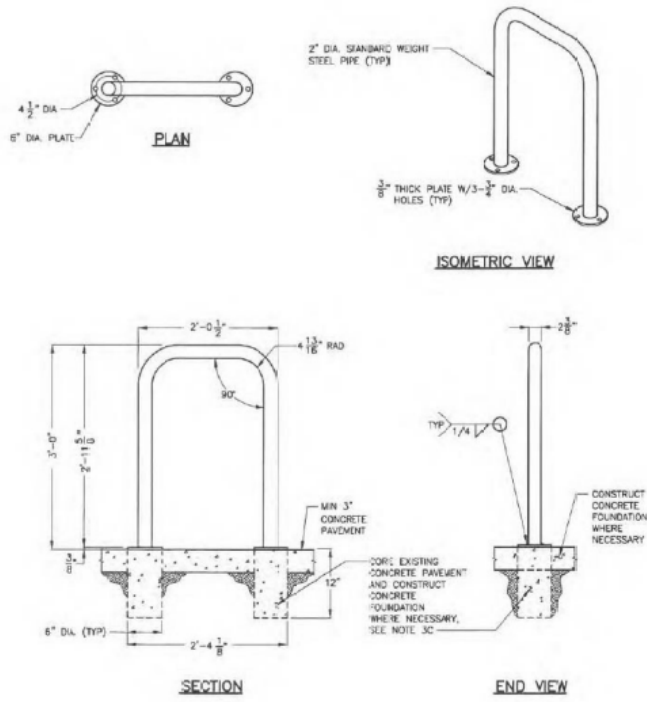

Figure 5. Bike Rack Details (Bid Alt 2)

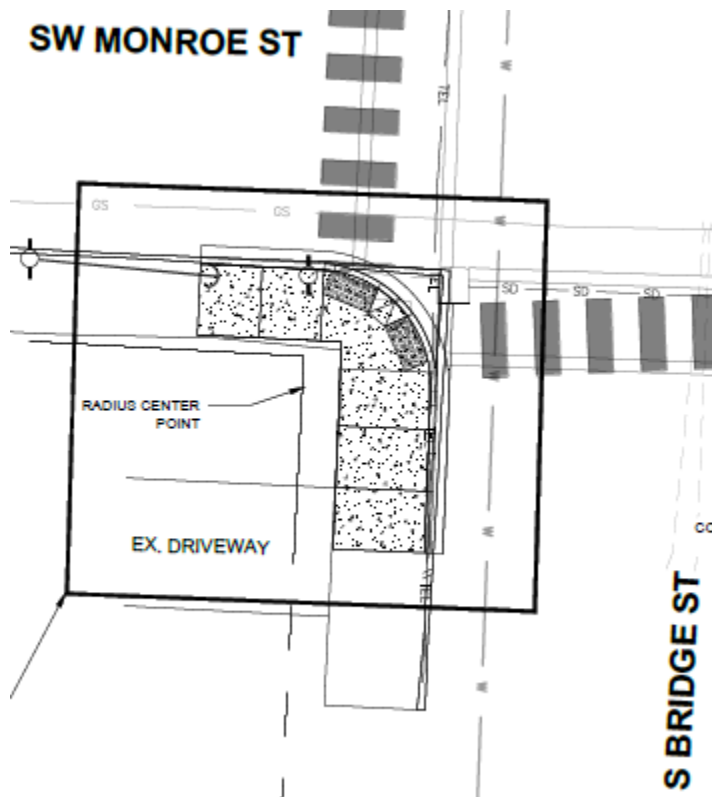

Figure 6. S Bridge St & SW Monroe St SW Corner ADA Ramp (Bid Alt 3)

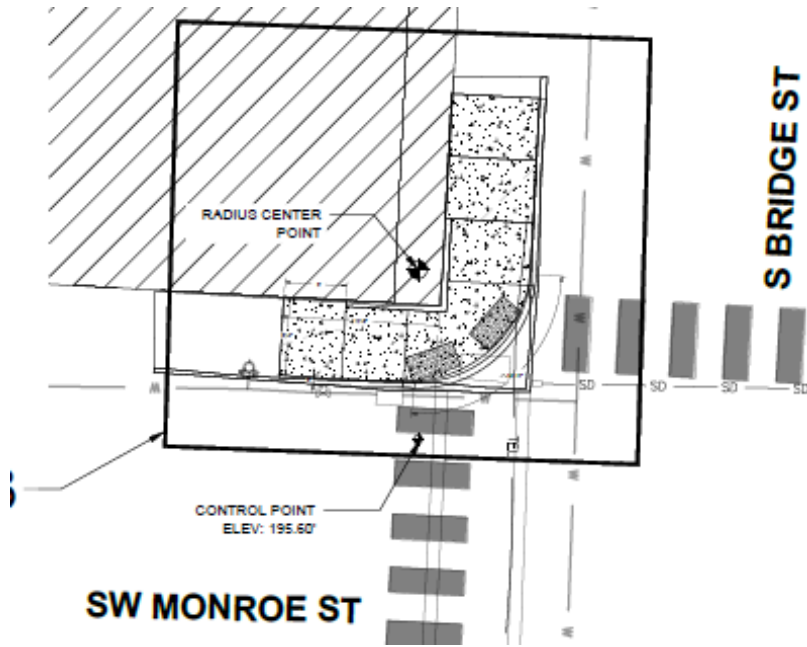

Figure 7. S Bridge St & SW Monroe St NW Corner ADA Ramp (Bid Alt 4)

## Mayor Cale George,

As requested, I am providing the following thoughts regarding the City-owned houses on Morgan and Mill Street. The process I envision starts with removing both houses using the Fire Department's Burn to Learn method as soon as it is safe to proceed. The Council has already approved removing the Morgan Street house. I urge the council to do the same with the Mill Street house. This should immediately be followed by clearing fire debris and garbage. Subsequently, I recommend that the city level, grade, gravel, and compact all four city lots to provide ample parking space for the downtown area and prepare the property for sale to a retail business interested in constructing offices or apartments upstairs. This property represents Sheridan's last major piece of real estate in the downtown core. I urge the City to make these lots available for businesses willing to work toward revitalizing and reinvigorating Sheridan's downtown.

The attached photos make me believe that rehabilitating the Mill Street house would be prohibitively expensive and not a good use of commercial land.

Thank you.  
Councilor Denny McElroy



Utility room is not ADA compliant and has inadequate lighting.



Single lightbulb in large room.



Floors at different levels downstairs would need to be raised or lowered to be ADA compliant.  
New flooring would be needed throughout.



Backdoor would need to be replaced with a wider ADA compliant door.



Arced and burnt GFI outlet.



Cloth covered two-strand wiring without ground.



Wiring with no ground. Difficult to tell if it is 12- or 14-gauge.



60 amp service panel is inadequate. Entire house would need to be rewired.



Dangerous electrical service would need to be completely replaced.



If the rodent droppings were cleaned up when the garbage was removed, this issue is continuing.



Outdated gas heater should be replaced. New heating and air conditioning would be needed.



Failing gutters approximately 40-feet around the house. Gutters would need to be replaced.



Asbestos siding failing. Broken pieces have fallen onto the ground. Several inefficient single pane windows would need to be replaced.



Failing asbestos siding. (back of the house sits on the ground with no foundation.)



Gas water heater in questionable condition. (Dated 3.9.2016)

**Further considerations:**

- Plumbing: lead and plastic pipes would need to be replaced. New water and sewer lines from the street would be needed.
- If used as City offices, front and back doors would need to be replaced with ADA compliant automatic doors. Bedroom, bathroom and garage entry doors would also need replacement with ADA approved doors.
- The upstairs area would be useless for anything but storage if the staircase is not replaced or a lift installed because it is not ADA compliant.
- A ramp would need to be built on the front of the house for ADA compliance.
- All appliances and light fixtures would need to be removed or replaced.
- The roof is marginal.
- New bathroom fixtures would be needed for ADA compliance.



**SUMMARY**  
127 SW Mill St, Sheridan OR 97378  
Heidi Bell  
January 6, 2022

Dan Stultz  
InterNACHI Certified Professional  
Inspector, IAC2 Mold and Radon  
Certified  
Craft Home Inspection  
503 550 8848  
dan@crafthi.com



#### 2.6.1 Asphalt Shingles

### **SHINGLES: LOOSE/MISSING POOR BOND- QC**

 **Serious Concern/Action Needed**

The asphalt roof had loose or missing shingles. This condition appeared to be due to failure of the shingle roof to bond adequately. Consult with a qualified contractor to determine the best course of action for these particular shingles. Failure to act soon may result in damage from roof leakage.

#### Recommendation

Contact a qualified roofing professional.

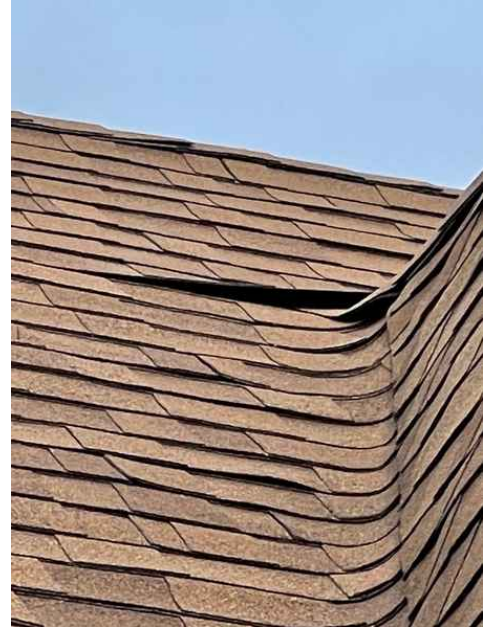

#### 4.1.2 Grounds

### **TREES: OVERHANGING LIMBS- QC**

 **Serious Concern/Action Needed**

Large trees near the house have branches that overhang the home. Falling limbs due to conditions such as wood decay, high winds or heavy snow loads may cause injury, death or damage. Significant weakening of large branches by conditions such as core decay may not be visible by persons without special training. Have these trees evaluated by a qualified arborist. Evaluating trees lies beyond the scope of the general Home Inspection.

#### Recommendation

Contact a qualified tree service company.



#### 4.2.2 Door/Window Exteriors

### **WINDOWS: BROKEN PANES- QC**

 **Serious Concern/Action Needed**

The home had multiple broken window panes. Consult with a qualified contractor to discuss options and costs for repair or replacement.

Recommendation  
Contact a qualified professional.



### 5.1.1 Service Drop **BUILDING CLEARANCE VIOLATIONS**

 **Serious Concern/Action Needed**

The overhead service drop conductors had inadequate clearance from portions of the home. For safety reasons, generally-accepted current standards require that these conductors maintain a minimum clearance of 3 feet (1m) from the following structures:

1. Sides of doors;
2. Porches;
3. Decks;
4. Stairs;
5. Ladders;
6. Fire escapes;
7. Balconies; or
8. Any portion of an operable window.

This home failed to comply with number(s) \_\_\_\_\_. The Inspector recommends that before the expiration of your Inspection Objection Deadline, you consult with your electrical service provider to discuss correction. Any work on the service conductors should be performed by a qualified personnel only.

Recommendation  
Contact a qualified professional.



### 5.3.1 Service Panel **MAIN DISCONNECT: 60 AMPS INADEQUATE**

 **Serious Concern/Action Needed**

The electrical service disconnect was rated at 60 amps. This is considered inadequate for a home with modern appliances. The Inspector recommends that before the expiration of your Inspection Objection Deadline you consult with a qualified contractor to discuss options and costs for upgrading to a larger service.

Recommendation  
Contact a qualified electrical contractor.

#### 5.4.1 Branch Circuits

### LIGHTING: LIGHT FIXTURE NO RESPONSE

 Serious Concern/Action Needed

An interior light fixture did not respond to the switch. The bulb may need to be replaced or there may be a problem with the switch, wiring or light fixture. If after the bulb is replaced this light still fails to respond to the switch, this condition may represent a potential fire hazard and the Inspector recommends that an evaluation and any necessary repairs be performed by a qualified electrical contractor.

#### Recommendation

Contact a qualified electrical contractor.



#### 5.4.2 Branch Circuits

### RECEPTACLE: HOT & NEUTRAL REVERSED- QC

 Serious Concern/Action Needed

An electrical receptacle had hot and neutral wires reversed. This condition should be corrected by a qualified electrical contractor.

#### Recommendation

Contact a qualified electrical contractor.



#### 5.4.3 Branch Circuits

### RECEPTACLE: OPEN GROUND- QC

 Serious Concern/Action Needed

An electrical receptacle had an open ground. Other receptacles in the home were grounded. This receptacle should have a functional equipment grounding conductor installed by qualified electrical contractor.

#### Recommendation

Contact a qualified electrical contractor.



#### 5.4.4 Branch Circuits

### RECEPTACLE: SCORCHING- QC



Serious Concern/Action Needed

An electrical receptacle was scorched. This condition indicates overheating and is a potential fire hazard. The Inspector recommends that an evaluation by an electrician and all necessary work be performed by qualified contractors.

#### Recommendation

Contact a qualified electrical contractor.



#### 5.4.5 Branch Circuits

### RECEPTACLES: MISSING COVER PLATES- QC



Serious Concern/Action Needed

At the time of the inspection, electrical receptacle cover plates were missing in various rooms in the home. This condition left energized electrical components exposed to touch, a shock/electrocution hazard. The Inspector recommends cover plates be installed by a qualified electrical contractor.

#### Recommendation

Contact a qualified handyman.



---

### 8.3.5 Kitchen

#### **WALLS: DAMAGE & DETERIORATION, SEVERE- QC**

 **Serious Concern/Action Needed**

Walls in the kitchen exhibited severe damage or deterioration. The Inspector recommends that before the expiration of your Inspection Objection Deadline you consult with a qualified contractor to discuss options and costs for repair.

Recommendation

Contact a qualified professional.



---

### 8.5.1 Stairs

#### **HANDRAIL ASSEMBLY: LOOSE- QC**

 **Serious Concern/Action Needed**

The handrail assembly at this staircase was loose. For safety reasons should be securely fastened by a qualified contractor.

Recommendation

Contact a qualified carpenter.





# **Bid**

Bigelow Construction LLC  
32643 west valley hwy.  
Sheridan OR 97378  
CCB # 216380

10/24/2023

127 sw mill st.  
Sheridan OR, 97378.

## Scope of Work:

-Upgrade all doors to 36" to meet ADA requirements. Replacement doors to be white paint grade, similar style to existing.

\$9,700.00

-Removal of flooring in first story. Replacement with maximum \$6sqf labor & material flooring to be chosen by client. Any unseen subfloor framing damage repair will be billed at time & materials (\$70hr)

\$7,200.00

-Interior walls/ceilings/doors/trim. To be cleaned, and painted. 1 color for trim. 1 color for walls/ceiling (unless otherwise specified by client).

\$6,700.00

-Kitchen dividing wall to be removed/supported with a beam to allow open access to kitchen space.

\$2,800.00

-Replacement of kitchen cabinets, with paint grade equivalent. Stainless steel sink/faucet

\$7,800.00

-Fill in framing in back room to allow flooring to remain at same elevation as the rest of the house.

\$5,500.00

Total:

\$39,700.00



To: City Council  
From: Heidi Bell, City Manager  
Date: September 9, 2024  
RE: Item C3) Vote: League of Oregon Cities 2025-2026 Legislative Priorities

The top five issues selected by the Council will be the City of Sheridan's recommendation to the LOC to focus on during the 2025-2026 legislative cycle. Attached is the tally sheet with the totals; the Council's top three are highlighted in green. The Council will need to discuss and decide on the fourth and fifth priorities for recommendation.

Sample Motion:

- ✓ I move to approve the City of Sheridan's top five recommendations and for the City Manager to provide this input to the LOC Board of Directors via a ballot submission before the September 27, 2024, at 5pm deadline.



# League of Oregon Cities 2025-2026 Priorities Ballot

Buckles      Acuff      Hebert      Hodgins      Houston      McElroy

## Community and Economic Development Committee

i Infrastructure Funding	I	I	I	I	II	II	total i: 8
ii Employment Lands Readiness and Availability	I	I			II		total ii: 3
iii Full Funding and alignment for Housing Production			I	I			total iii: 2

## General Government Committee

iv Behavioral Health Enhancements						I	total iv: 1
-----------------------------------	--	--	--	--	--	---	-------------

## Energy and Environment Committee

v Investvestment in Community Resiliency and Climate Planning Resources							total v: 0
vi Address Energy Affordability Challenges from Rising Utility Costs	I		I	I	I		total vi: 4

## Finance and Taxation committee

vii Marijuana Tax				I		I	total vii: 2
viii Alcohol Tax			I	I			total viii: 2

## Broadband, Cybersecurity, AI, and Telecommunications Committee

ix Resilient, Futureproff Broadband Infrastructure and Planning Investment	I						total ix: 1
--	---	--	--	--	--	--	-------------

## Transportation Committee

x 2025 Transportation Package		I			I		total x: 2
xi Funding and Expanding Public and Inter-Community Transit			I				total xi: 1
xii Shift from a Gas Tax to a Road User Fee	I	I				I	total xii: 2

## Water and Wastewater Committee

xiii Operator-in-Training Apprenticeships	I	I					total xiii: 2
---	---	---	--	--	--	--	---------------



To: Sheridan Mayor and City Council  
From: Heidi Bell, City Manager  
Date: September 9, 2024  
RE: Item D1) Purchasing Presentation

At the September Special Session, I will give an oral presentation about City purchasing. I have completed an in-depth review of city expenditures from July 2024 through July 2025.

For harmony between staff, Council, and the public it is important that we have a clear, formalized policy about the City's purchasing, both for services and goods. I will give an oral presentation to the Council at the September 9, 2024, meeting giving an overview of the considerations for creating a Buying Local policy.

The League of Oregon Cities, *Oregon Municipal Handbook, Chapter 3: Municipal Officials*<sup>1</sup> serves as a guiding document for the roles and responsibilities of city officials; this includes mayors, councilors, and city managers. Locally, the City of Sheridan's Charter and Ordinances are essential for following to ensure that the system is running smoothly and as the public intends. The other consideration is the *Oregon Municipal Handbook, Chapter 13: Purchasing & Public Contracts*<sup>2</sup>; these rules are also included in your packets.

The City of Sheridan's Council and City Manager are stewards of the City's resources, like money. Below are the relevant provisions from the *Sheridan Municipal Code, Chapter 2.08 City Manager*<sup>3</sup> (a copy of which is attached), that refer to the economic duties of the City Manager. Specifically, SMC 2.08.040, subsections F, H, and N provide:

F. To exercise spending authority for line items approved in the adopted city budget, and exercise discretionary spending authority of not more than one thousand dollars (\$1,000.00) for unspecified expenditures within adopted budget accounts other than contingency accounts;

H. To seek out economic and community development opportunities for council review and action;

N. To ensure that provisions of all franchises, agreements, contracts, leases, permits or other agreements and privileges granted by, or entered into, by the city, are enforced and observed;

On August 7, 2023, to provide further clarity, the Council discussed and approved Resolution No. 2023-DD, *A Resolution Adopting a Purchasing Policy for the City of Sheridan*<sup>4</sup> and Resolution No. 2023-EE, *A Resolution Defining Roles and Functions of Mayor, City Council, and Mayor*<sup>5</sup>. Both are attached for your reference in case you want to make changes. At that time, Mayor Thomson explained to the City Council the purchase procedures and the scrutiny invoices and checks receive; which have not changed. The minutes<sup>6</sup> for that meeting are also included.

The Oregon Ethics laws also apply to purchases. Annually, I take the Oregon Government Ethics Commission's course to ensure that I am always familiar and updated with any changes, as should anyone that is a steward of public funds.

At the conclusion of my presentation, my recommendation will be to form a small group that will draft a revised purchasing policy, to be referred to the Council for adoption. I think it will be best to have a couple of councilors, me, and a few staff persons (including finance and a couple from public works). It might be good to have a person from the Budget Committee join too. What do you think?

I am happy to answer questions (people often don't ask me). Make me a to-do list, set up a meeting and we can go through the expenses, or pick a time to come in and go through the invoice files. For more efficient and productive council meetings, please ask me beforehand.

Since I have been here, there has never been a need for a budget adjustment, let alone a supplemental budget. I have raised the City's credit rating to an A+ and I have had an unmarked audit both times. I take city finances very seriously, and if I have a question about staff expenses, I get to the bottom of it.

The message I want to deliver is that I am happy for change and feedback, please let me know what I can do better to serve my community.

Attachments:

1. *Oregon Municipal Handbook, Chapter 3: Municipal Officials*
2. *Oregon Municipal Handbook, Chapter 13: Purchasing & Public Contracts*
3. *Sheridan Municipal Code, Chapter 2.08 City Manager*
4. Resolution No. 2023-DD, *A Resolution Adopting a Purchasing Policy for the City of Sheridan*
5. Resolution No. 2023-EE, *A Resolution Defining Roles and Functions of Mayor, City Council, and Mayor*
6. Excerpt from City Council Minutes, dated August 7, 2023